

OBRIEN

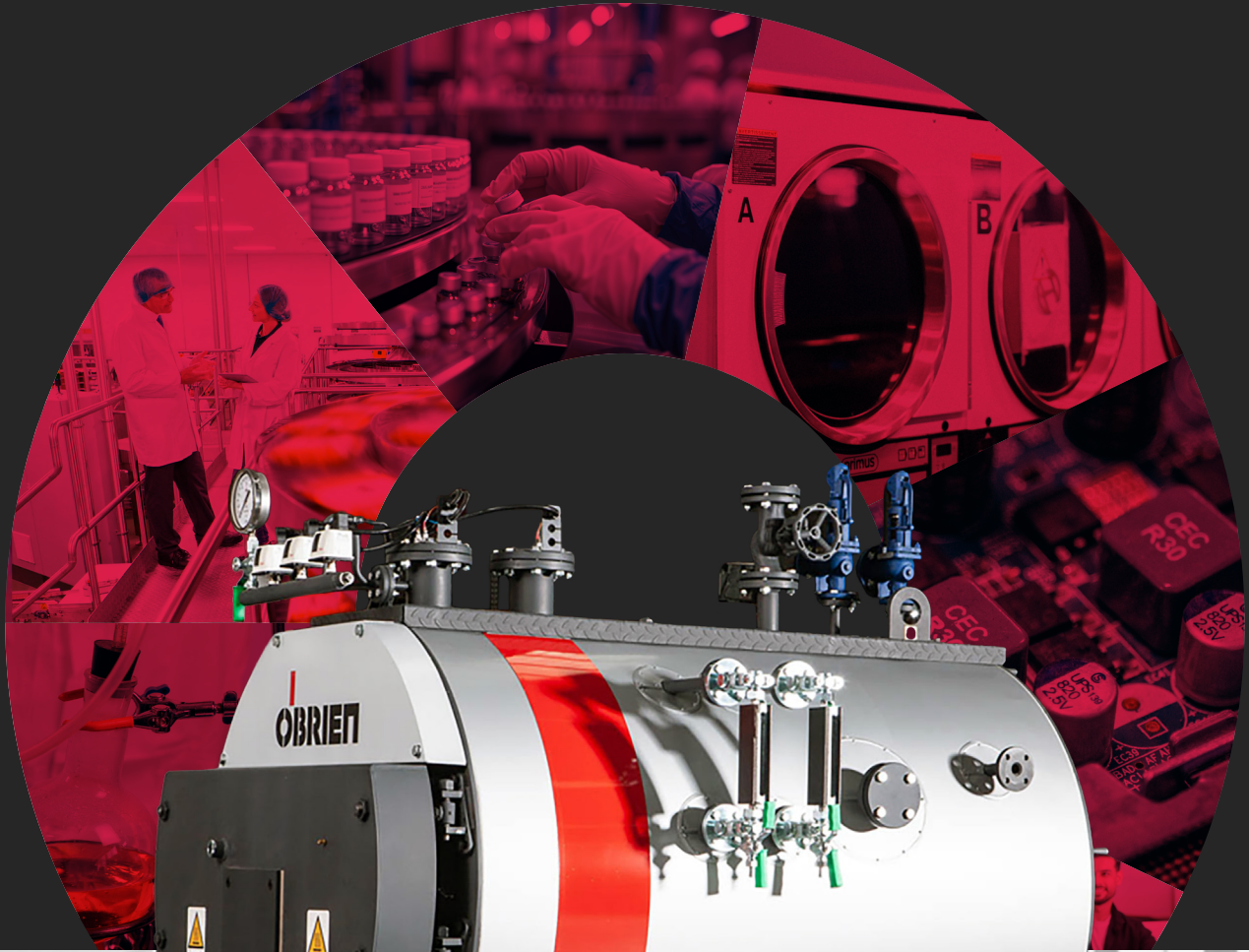

OBYONE
Firetube Steam Boiler

Powerful, Precise, Unstoppable



OBRYONE Firetube Steam Boiler

Packaged smoke tube steam boiler — three pass, reversed flame, wet back. 300 to 6000 kg/h. Up to 12 bar. Liquid or gaseous fuels. Auto operation ready.

98%

Peak Efficiency

12 Bar

Std. Working Pressure

300-6000

Steam kg/h

3 Pass

Reversed Flame

Design Features

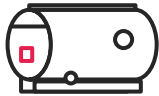

Boiler Body

- Cylindrical shell
- Wet back furnace
- High quality steel



Smoke Tubes

- Steel turbulators or aluminium/ steel inserts — as required



Front Door

- Welded steel
- Insulation + refractory lining
- Reversible opening



Rear Smoke-Box

- Easy access
- cleaning door
- Pre-arranged for integral economiser

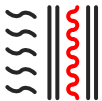

Thermal Insulation

- Dual rock wool layers with aluminium foil
- Thermal bridge elimination



Gangway

- Checker plate — upper part access



Panel Boards

- Electromechanical and electronic
- expandable



Burner Compatibility

- One, two, three stage or modulating burners

Design Features

1. Boiler body
2. Front door
3. Panel board
4. Instruments assembly
5. Level Safety sensors
6. Capacitive level transmitter (IML)
7. Steam throttle
8. Safety valve
9. Rear smoke chamber
10. Drain
11. Pumping feeding group
12. TDS connection
13. Level gauge

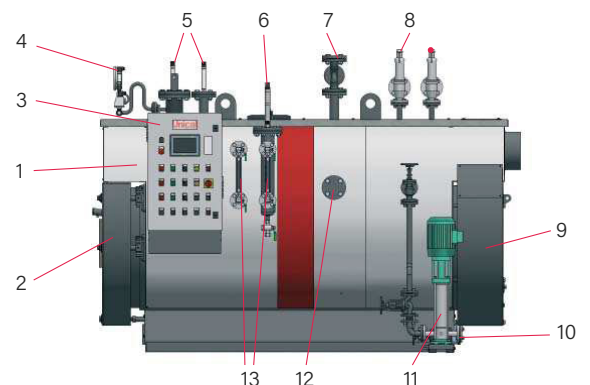

Technical Specifications

Model Breakdown

Model (kg/h)	Nominal Input (kW)	Output STD (kW)	Max Pressure (bar)	Water Content (L)
300	204	234	12	540
400	273	314	12	540
500	341	392	12	820
600	409	470	12	820
800	560	644	12	1080
1000	700	805	12	1080
1250	852	979	12	1555
1500	1022	1175	12	1555
2000	1363	1597	12	2005
2500	1704	1926	12	2890
3000	2045	2310	12	2890
4000	2726	3133	12	4155
5000	3048	3917	12	5800
6000	4089	4700	12	6760

* Feeding water temperature = 80°C · Pressure = 12 bar

Operating Parameters

Performance	
Steam Production Range	300–6,000 kg/h
Standard Max. Working Pressure	12 bar
Higher Pressure	Available on request
Peak Efficiency	Up to 98% with ESALU & economiser
Fuel Type	Liquid or gaseous

Connection	
Burner Head Min. Length	340–370 mm
Burner Head Max. Diameter	210–420 mm
Smoke Side ΔP	2.2–8.8 mbar

Lower carbon, lower cost, higher reliability — through engineered energy systems.

Delivered & Commissioned



2x500kW OBYONE Steam Boiler
Cleanaway, 126 Barry Road,
CAMPBELLFIELD VIC 3061



2xOBYONE S 3500 Steam Boiler
JBS, 2 Regulator Rd,
Yanco NSW 2703



500KW OBYONE800 Steam Boiler
M&KH Trading,
NSW



4000kW OBYONE3P-6000 Steam Boiler,
Westex Investment (Western Meat Exporter),
60 Warrego Hwy, Charleville QLD

Why O'Brien?

- **Australia's Largest**

Leading supplier of industrial boilers across Australia

- **20+ Years Experience**

Decades of engineering expertise in steam & hot water systems

- **24/7 Support**

Around the clock support with instant phone assistance

- **Accredited Training**

RTO Code 45484, boiler operation training nationwide

- **Tailored Solutions**

Custom engineered, with no off the shelf compromises

- **765+ Active Clients**

Trusted across Australia and internationally

Ready to engineer your energy solution?

Connect with us at

 1300 771 759

 obrien-energy.com.au

 sales@obrien.energy

Follow us on:

